

# TEMPERATURE SENSOR

## WT-111

### Applications:

The insert is design as a replaceble element of terminal head sensors. In some applications it can be used without thermowell.

### Technical Data

|                          |   |
|--------------------------|---|
| Measuring range          | according to resistor type<br>max 600°C     |
| Resistance element:      | Pt100 up to PN-EN 60751+A2<br>Pt1000, Pt500 |
| Protection tube material | stainless steel 1H18N9T (1.4541)            |
| Protection tube diameter | ∅ 4; 5; 6 mm and others                     |
| Protection tube length   | according to thermowell length              |
| Connection line          | 2, 3 or 4-wire                              |

### Ordering code

|                           |   |     |   |  |   |  |   |  |   |  |   |            |
|---------------------------|---|-----|---|--|---|--|---|--|---|--|---|------------|
| WT                        | - | 111 | - |  | - |  | - |  | - |  | - |            |
| Protection tube dia. d    |   |     |   |  |   |  |   |  |   |  |   |            |
| ∅ 6 mm                    |   |     |   |  |   |  |   |  |   |  |   | 6          |
| others                    |   |     |   |  |   |  |   |  |   |  |   |            |
| Protection tube length Lw |   |     |   |  |   |  |   |  |   |  |   |            |
| 330 mm                    |   |     |   |  |   |  |   |  |   |  |   | 330        |
| others                    |   |     |   |  |   |  |   |  |   |  |   |            |
| Connection line           |   |     |   |  |   |  |   |  |   |  |   |            |
| 2-wire, 3-wire, 4-wire    |   |     |   |  |   |  |   |  |   |  |   | e.g. 2     |
| Tolerance                 |   |     |   |  |   |  |   |  |   |  |   |            |
| class - A, B, 1/3B        |   |     |   |  |   |  |   |  |   |  |   | e.g. B     |
| Measuring insert          |   |     |   |  |   |  |   |  |   |  |   |            |
| Pt100, 2xPt100, others    |   |     |   |  |   |  |   |  |   |  |   | e.g. Pt100 |
| Operating temperature     |   |     |   |  |   |  |   |  |   |  |   |            |
| 80°C, 200°C, others       |   |     |   |  |   |  |   |  |   |  |   | e.g. 200°C |

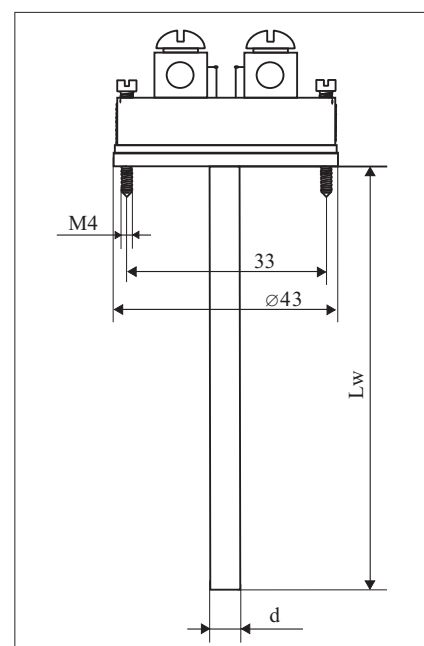

### Order example:

WT-111-6-330-2-B-Pt100-200°C - sensor of protection tube diameter d=6 mm, Lw length =330 mm, 2-wire, class B, Pt100, operating temperature 200°C.